



engineered  
to perform

e

many models  
in stock

✓

durability  
for decades

10

## QBD Series Direct-Drive Portable Barrel Fans

Triangle Engineering's QBD Series is an economy line of direct-drive portable barrel fans, delivering reliable airflow at an affordable price. Built with a rugged steel barrel, OSHA-compliant spiral-wound guards, and deep-pitch blades, the QBD provides steady, economical cooling for shops, warehouses, and work areas without the short life cycle of disposable imports. Each unit ships fully assembled and performance-tested, ready to roll into place and plug in, no complicated setup required. With two-speed airflow control, large no-flat wheels, and stocked replacement parts, the QBD delivers dependable, high-volume cooling for commercial facilities and agricultural operations alike.

### KEY FEATURES

- Direct-drive simplicity, no belts or pulleys to maintain
- Two-speed motor for adjustable high/low airflow
- Deep-pitch steel blades for high-volume air delivery
- Rugged steel barrel construction
- OSHA-compliant spiral-wound guards
- Large no-flat wheels for easy maneuverability

### IDEAL USE CASES

- **Warehouses & Light Industrial:** Move large volumes of air across open floor plans
- **Fabrication Shops & Service Bays:** Cool work areas and improve air circulation
- **Workstation & Assembly Line Cooling:** direct airflow where crews need it most, increasing productivity
- **Agricultural Barns & Equipment Sheds:** Durable, dependable cooling built for demanding environments

## Why QBD?

### Reliability and Durability

Built in the USA with a blend of domestic and foreign components, Triangle Engineering has been an industry leader since 1948. Unlike disposable imports, QBD fans are designed to be maintained, not thrown away. Every unit is backed by stocked replacement parts and fast support so your fan stays running, not sitting.

### Direct-Drive Simplicity

With no belts or pulleys to adjust, tension, or replace, the QBD keeps maintenance simple and downtime short. Deep-pitch steel blades move serious air volume while the direct-drive motor provides straightforward, dependable performance, plug in, choose your speed, and get to work.

### Economical Performance

The QBD Series puts high-volume air movement within reach at an economy price point without sacrificing the build quality or serviceability you expect from Triangle Engineering.

## Technical & Performance Specifications

- ▶ **Blade Diameters**  
36" and 42"
- ▶ **Airflow (CFM)**  
36": 10,900 (high) / 8,800 (low)  
42": 13,200 (high) / 10,200 (low)
- ▶ **Motor**  
½ HP, two-speed | 6.1 Amps
- ▶ **Electrical**  
115V single-phase plug-and-play operation
- ▶ **Drive System**  
Direct drive
- ▶ **Fully Assembled & Performance-Tested**  
Ready to roll into place and plug in.  
No assembly required.

## QBD Ordering & Model Information

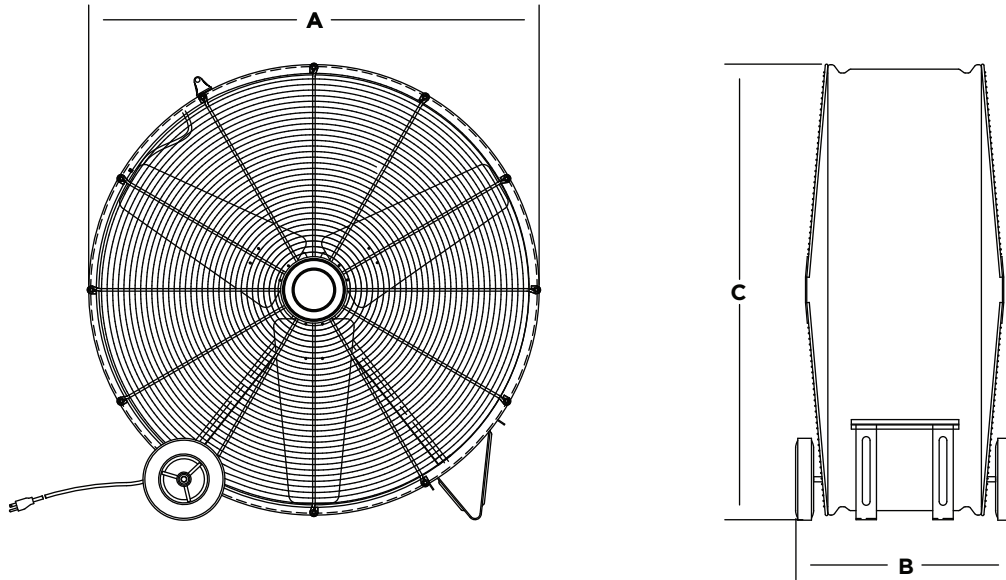

Model	Blade Diameter	CFM	RPM	HP	Amps	Width A	Depth B	Height C	Approximate Weight
QBD3623	36"	10,900 / 8,800	800 / 725	1/2	6.1	39"	21"	40"	96
QBD4223	42"	13,200 / 10,200	800 / 725	1/2	6.1	45"	21"	45"	101

## Built to Last, Not to Toss

Every QBD fan is fully supported with stocked replacement parts: motors, guards, blades, wheels, and switches, so maintenance is fast and downtime stays short. The QBD Series is built to be serviced, not tossed, keeping your fan in operation for years instead of ending up in a landfill.

While low-cost imports flood the market with disposable fans, Triangle Engineering builds portable cooling that's designed for the long haul, with real replacement parts, real support, and real durability behind every unit.

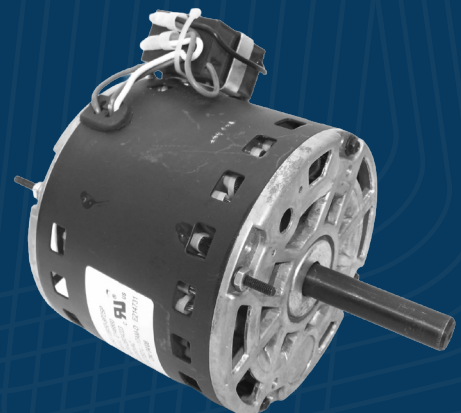

# Why Choose Triangle Engineering?

## A Legacy of Quality Since 1948

For more than seven decades, we have specialized in crafting top-tier ventilation products that stand up to demanding industrial environments. Our fans are factory-assembled, rigorously tested, and supported by an experienced customer service team.

## More Portable Cooling Options

Need more power, a different size, or a mounted configuration? Triangle Engineering offers a complete range of portable barrel fans, belt-driven and direct-drive, floor-standing and wall or ceiling mounted across a wide range of diameters and horsepower options. Contact us to learn more.

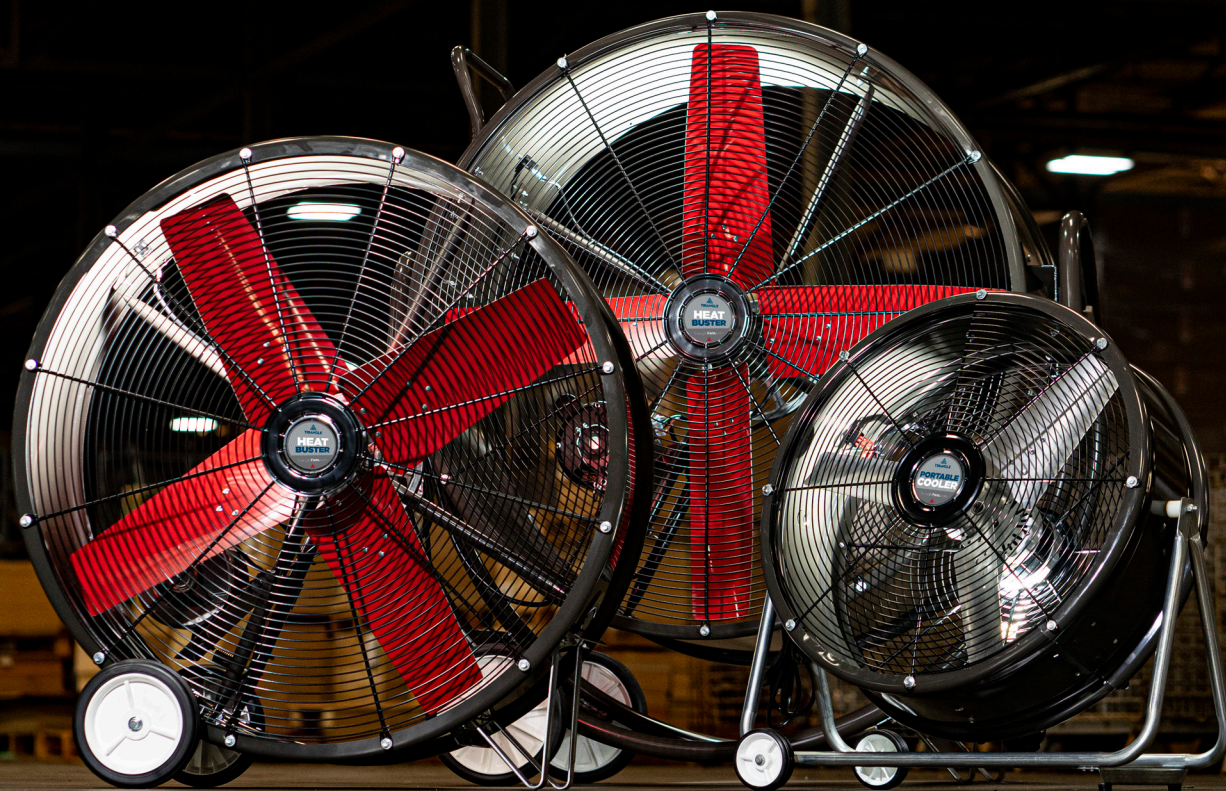

1101 North Redmond Road, Jacksonville, AR 72076  
(501) 982-7558 ► [TriangleFans.com](http://TriangleFans.com)