



engineered
to perform

e

90% built
in 7 days

7

durability
for decades

10

PC Series Portable Cooler HD

Direct-Drive Portable Barrel Fans

Triangle Engineering's PC Series Portable Cooler HD is a heavy-duty direct-drive portable barrel fan built for brutal heat and demanding environments. A rugged painted-steel barrel with a roll-formed "ogee" profile resists deformation during everyday abuse, while deep-pitch steel blades and a direct-drive motor deliver relentless high-velocity airflow without belt upkeep. Available in 36", 42", and 48" diameters with ½ HP and 1 HP motor options, the Portable Cooler HD scales to the job at hand. Each unit ships fully assembled and performance-tested, ready to get to work on day one, no complicated setup required. With factory-stocked replacement parts, OSHA-compliant guards, and flexible electrical configurations, the PC Series delivers serious industrial cooling you can count on.

KEY FEATURES

- Direct-drive simplicity, no belts or pulleys to maintain
- Two-speed motor options for adjustable high/low airflow
- Deep-pitch steel blades for high-volume air delivery
- Heavy-duty painted-steel barrel with roll-formed "ogee" profile for added rigidity
- OSHA-compliant spiral-wound guards

IDEAL USE CASES

- **Warehouses & Distribution Centers:** Move massive volumes of air across open floor plans and cross-dock lanes
- **Fabrication Shops & Service Bays:** Cool work areas and improve air circulation
- **Rental Fleets & Event Cooling:** Rugged, portable units built to handle job-site and temporary deployment
- **Agricultural & Processing Facilities:** Durable, dependable cooling built for demanding conditions

Why PC?

Reliability and Durability

Built in the USA with a blend of domestic and foreign components, Triangle Engineering has been an industry leader since 1948. Unlike disposable imports, PC Series fans are designed to be maintained, not thrown away. Every unit is backed by stocked replacement parts and fast support so your fan stays running, not sitting.

Heavy-Duty, High-Velocity Performance

The Portable Cooler HD is built to take on brutal heat in the toughest environments. A roll-formed "ogee" barrel profile adds stiffness and shrugs off everyday abuse, while deep-pitch steel blades push up to 19,100 CFM of high-velocity air. Direct-drive simplicity means no belts to tension, no pulleys to align, just dependable, powerful airflow.

Flexible Power Options

From standard 115V plug-and-cool operation to 230V single-phase and 230/460V three-phase configurations, the PC Series adapts to any power scheme. Choose ½ HP for efficient cooling or step up to 1 HP for maximum air delivery in the most demanding applications.

Technical & Performance Specifications

- ▶ **Blade Diameters**
36", 42", and 48"
- ▶ **Airflow (CFM)**
10,900 - 19,100 (model and HP dependent)
- ▶ **Motor**
½ HP (single- or two-speed) or
1 HP (single-speed)
- ▶ **Motor Type**
Open Drip Proof (ODP) or
Totally Enclosed Fan-Cooled (TEFC)
- ▶ **Electrical**
115V single-phase cord & plug (standard);
230V 1-ph and 230/460V 3-ph available
- ▶ **Drive System**
Direct drive with sealed ball bearings
- ▶ **Fully Assembled & Performance-Tested**
Ready to roll into place and plug in.
No assembly required.



PC Ordering & Model Information

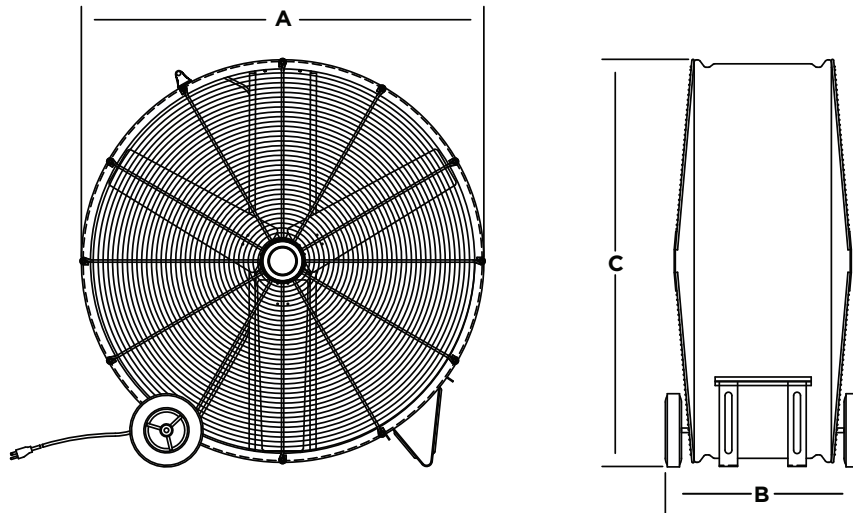

Model	Blade Diameter	CFM	RPM	HP	Amps	Width A	Depth B	Height C	Approximate Weight
PC3613	36"	10,900	825	1/2	6.0	39"	21"	40"	111
PC3623	36"	10,900 / 8,800	825 / 680	1/2	6.0	39"	21"	40"	111
PC4213	42"	13,600	825	1/2	6.0	45"	21"	46"	121
PC4223	42"	13,600 / 10,500	825 / 680	1/2	6.0	45"	21"	46"	121
PC4815	48"	19,100	850	1	9.1	51"	25"	52"	193

Built to Last, Not to Toss

Every PC Series fan is fully supported with stocked replacement parts: motors, blades, guards, and wheels, so maintenance is fast and downtime stays short. The Portable Cooler HD is built to be serviced, not tossed, keeping your fan in operation for years instead of ending up in a landfill.

While low-cost imports flood the market with disposable fans, Triangle Engineering builds portable cooling that's designed for the long haul with real replacement parts, real support, and real durability behind every unit.



Why Choose Triangle Engineering?

A Legacy of Quality Since 1948

For more than seven decades, we have specialized in crafting top-tier ventilation products that stand up to demanding industrial environments. Our fans are factory-assembled, rigorously tested, and supported by an experienced customer service team.

More Portable Cooling Options

Need more power, a different size, or a mounted configuration? Triangle Engineering offers a complete range of portable barrel fans, belt-driven and direct-drive, floor-standing and wall or ceiling mounted across a wide range of diameters and horsepower options. Contact us to learn more.

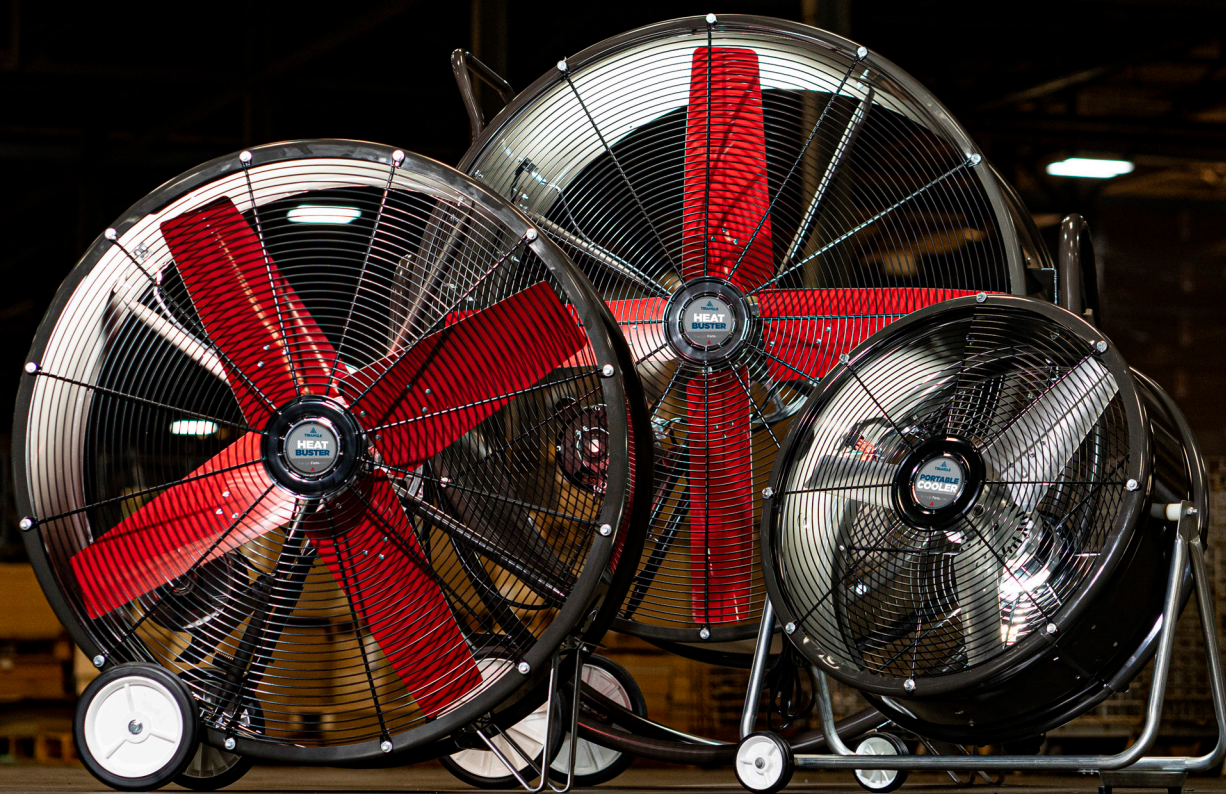

1101 North Redmond Road, Jacksonville, AR 72076
(501) 982-7558 ► TriangleFans.com