



THE RV SERIES

Triangle's "RV" Series Belt Drive Industrial Wall Supply Fans are designed with long lasting performance in mind and are well suited for supplying factories, gymnasiums, and warehouses. Each of our "RV" Series Industrial Wall Supply Fans come standard with automatic belt tensioning to reduce maintenance and to extend motor and belt life.

Features

- Belt drive
- Rolled venturi for improved airflow
- Durable polyester powder coated finish
- High quality, heavy duty components
- Automatic belt tensioner
- Optional temperature (40F° - 110F°) control (sold separately)

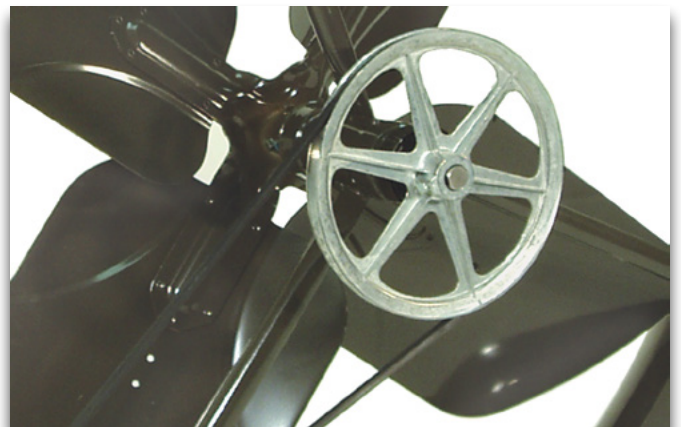
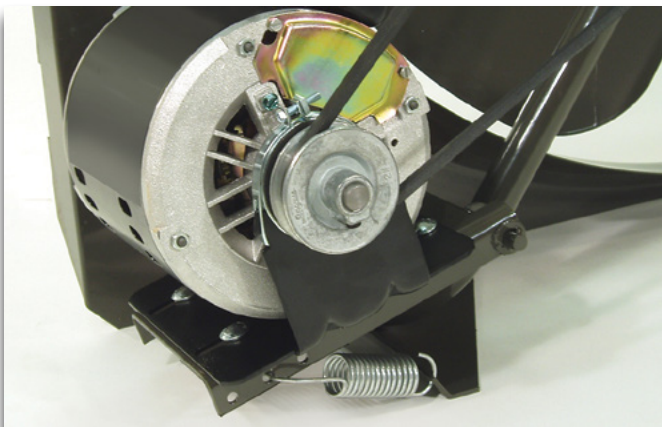

Diameter	HP	CFM 0.0 SP	0.125 SP	0.25 SP	Approximate Weight	1-Phase		3-Phase
						Open Drip Proof Motor 115V	Totally Enclosed Motor 115/230V	Open Drip Proof Motor 230/460V
24"	1/3	3,920	2,070	930	53	RV2412-V		
30"	1/3	6,420	4,980	1,790	55	RV3012-V		
	1/2	9,560	7,770	4,850	68	RV3013-V	RV3013T-U	RV3013-X
36"	1/2	10,900	9,160	4,310	71	RV3613-V	RV3613T-U	RV3613-X
42"	1/2	14,200	11,600	5,470	90	RV4213-V	RV4213T-U	RV4213-X
48"	1/2	17,100	11,500	3,900	106	RV4813-V	RV4813T-U	RV4813-X
	3/4	18,100	13,800	6,370	110	RV4814-U*		

*All weights are approximate and measured in pounds

*Dual Voltage, single phase and prewired 115v

Dimensions "RV" Series			
Diameter	(A)	(B)	(C)
24"	30"	30"	16 1/4"
30"	34"	34"	16 1/4"
36"	40"	40"	16 1/4"
42"	46"	46"	16 1/4"
48"	52"	52"	16 1/4"

OPTIONAL TEMP CONTROL	
Thermostat	TS-115/230-1

TS-115/230-1: Only compatible with single phase motors up to 1 HP

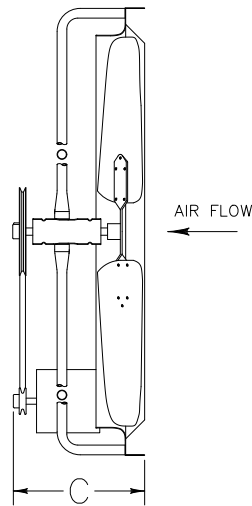
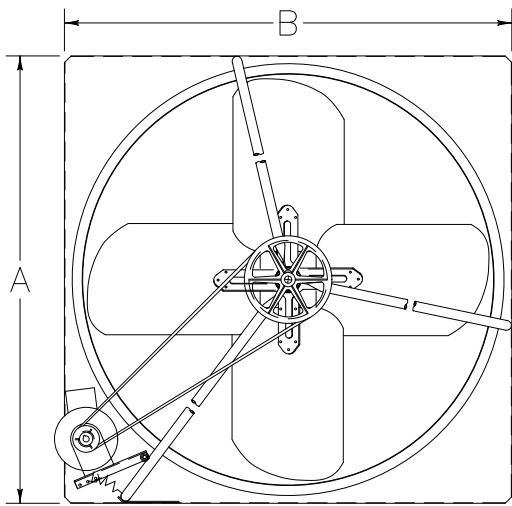

Performance shown is for installation type A: free inlet and free outlet and does not include the effects of accessories
All units are made to order and are not returnable