

DISCHARGE VIEW

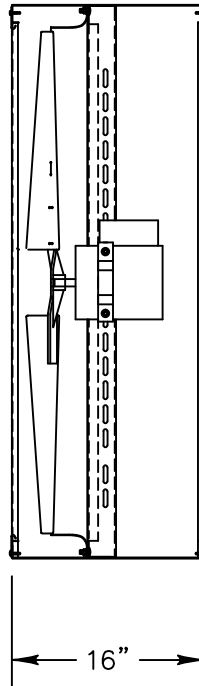

1' X 2" BIRD SCREEN ON
INTAKE AND DISCHARGE SIDES

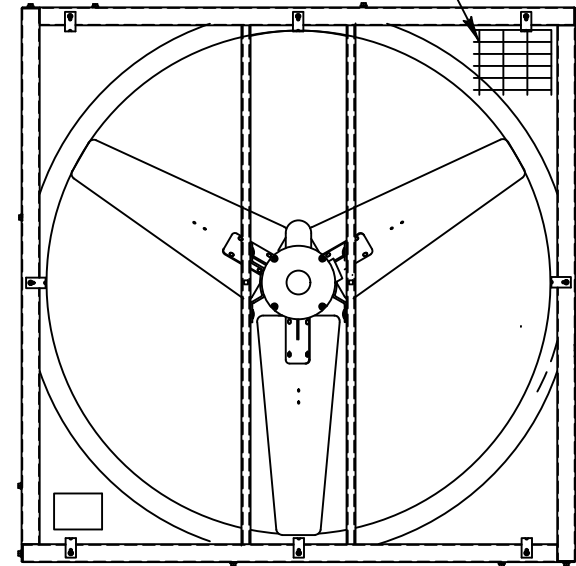

INTAKE VIEW

Fan Specifications

Blade Diameter:	42"	Motor Enclosure:	TEAO
Drive:	Direct	Duty Cycle:	Continuous Duty
Horsepower:	1	Guards:	1"X2" Bird Screen
Voltage:	230/460	Power Cord:	N/A
Phase:	3		
RPM:	833		

*See TriangleFans.com for performance specifications

*Specifications are subject to change without notice



PFG4215D-460

NOT TO SCALE | 2 AUG 2004