

DISCHARGE VIEW

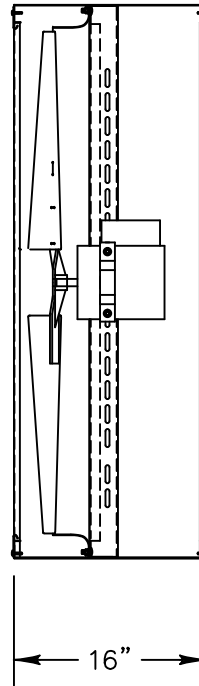

1' X 2" BIRD SCREEN ON  
INTAKE AND DISCHARGE SIDES

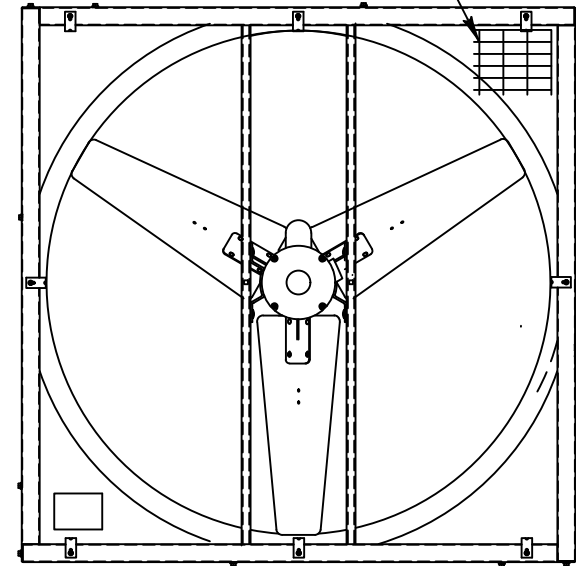

INTAKE VIEW

## Fan Specifications

Blade Diameter:	36"	Motor Enclosure:	TEAO
Drive:	Direct	Duty Cycle:	Continuous Duty
Horsepower:	1	Guards:	1"X2" Bird Screen
Voltage:	230	Power Cord:	10' with molded plug
Phase:	1		
RPM:	843		

\*See TriangleFans.com for performance specifications

\*Specifications are subject to change without notice



PFG3615D

NOT TO SCALE | 2 AUG 2004