



THE GENTLE BREEZE

Triangle's Gentle Breeze is the largest, most ruggedly built portable fan on the market today. It quietly delivers a gentle breeze at distances up to 150 feet! It is so quiet you can easily carry on a normal conversation. It is easy to move for optimal breeze direction and is ideal for assembly lines, work areas, warehouses and sporting events.

Features

- Extra quiet 60dBa at 20' from the fan
- OSHA compliant woven wire guards
- Powder coat finish for resistance to weather and corrosion, indoors or out
- Single-phase and three-phase models available
- Ships completely assembled
- 20' grounded three conductor cord with molded plug



GENTLE BREEZE

Model	Volts	Phase	AMPS	Fan Weight	Shipping Weight
GB8415-V	115	1-Phase	10	680	1030
GB8415-W	230	1-Phase	5		

GB WITH SPEED CONTROL

Model	Volts	Phase	AMPS	Fan Weight	Shipping Weight
GB8415SC-V	115	1-Phase	10	700	1050
GB8415SC-W	230	1-Phase	5		

GENTLE BREEZE DIMENSIONS

Dimensions	A	B	C
Fan	95"	96"	35"
Crate	103"	101"	42"
Speed	220 RPM		
Sound Level	60dBa at 20' From Fan		

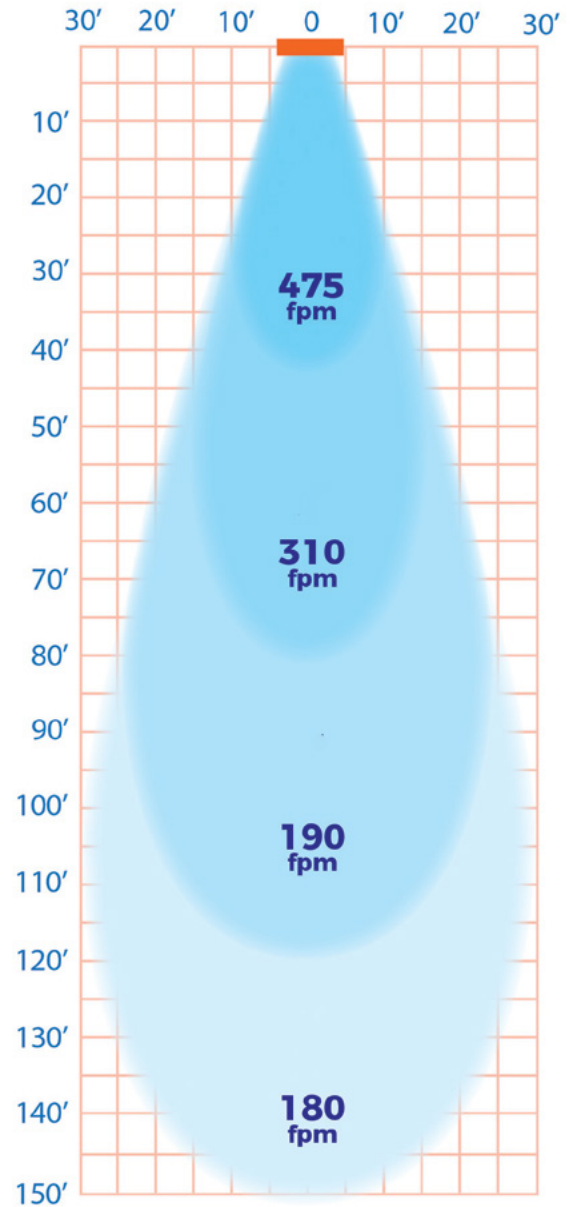
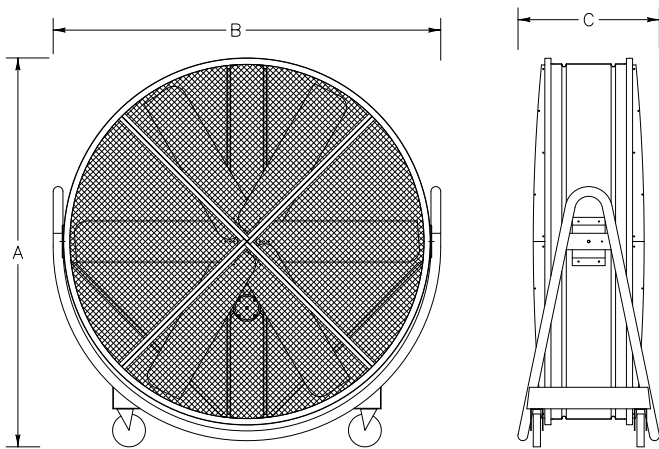

- Air speeds are the average velocity for each zone
- Air speeds were measured 67" from the floor
- FPM = Feet per minute

Testing performed in a controlled environment. Actual airflow may vary due to operating environment

PORTABLE FANS: GENTLE BREEZE

sales@trianglefans.com ▶ 501-982-7558 ▶ TriangleFans.com