



GENERAL PURPOSE EXHAUST FANS

Triangle's General Purpose Exhaust fans are ruggedly designed for continuous operation for exhausting workshops, barns, poultry houses, greenhouses, garages or anywhere air movement is required to control condensation and exhaust stagnant air.

Features

- Available with 12," 16," 20," 24" and 30" fan blades.
- Ships fully assembled and ready to install
- 115 volt totally enclosed air over (TEAO) thermally protected motor
- Heavy gauge galvanized steel frame to reduce rust and corrosion
- Built-in shutter with rigid blades for long lasting, continuous operation
- Spiral guard has a polyester powder coat finish and meets OSHA requirements
- Shutter opens and closes automatically when the fan is turned on and off
- Optional temperature (40F° - 110F°) control (sold separately)

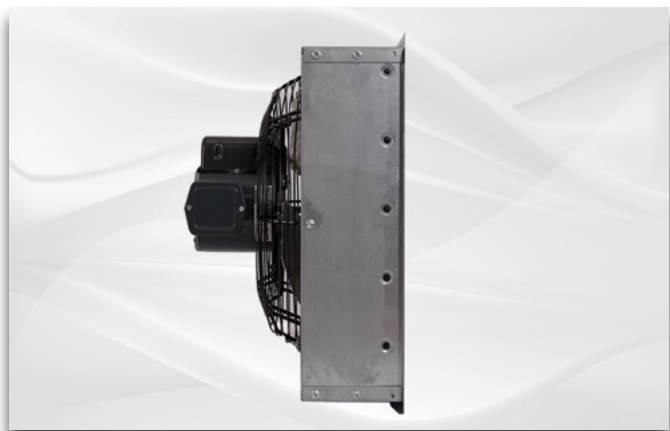

GPX SERIES

Model	Diameter	CFM	RPM	HP	Amps
GPX1210	12"	1,580	1625	1/6	2.2
GPX1611	16"	2,600	1650	1/4	2.3
GPX2011	20"	3,200	1650	1/4	2.3
GPX2413	24"	5,460	1100	1/2	6.1
GPX3013	30"	6,800	1100	1/2	6.1

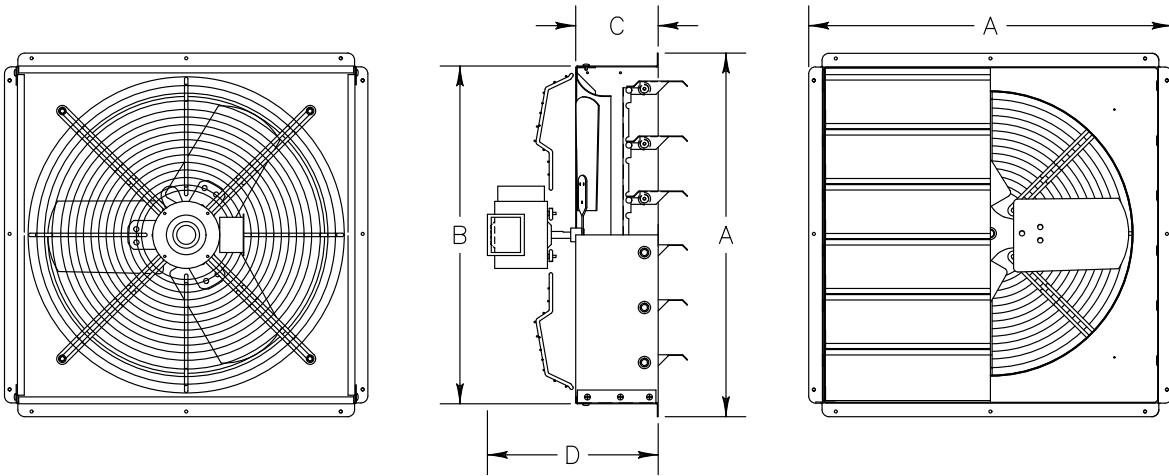

GPX Fan Dimensions

Model	A	B	C	D
GPX1210	18 3/4"	17 1/8"	6"	13 1/4"
GPX1611	22 3/4"	21 1/8"	6"	13"
GPX2011	26 3/4"	25 1/8"	6"	13"
GPX2413	30 3/4"	29 1/8"	6"	14 1/4"
GPX3013	36 3/4"	35 1/8"	6"	13"

GPX Shipping Dimensions

Model	Height	Width	Depth	Weight (lbs)
GPX1210	19"	14"	19"	35
GPX1611	23"	14"	24"	43
GPX2011	27"	14"	28"	55
GPX2413	31"	16"	32"	66
GPX3013	40"	16"	40"	70

OPTIONAL TEMP CONTROL

Thermostat

TS-115/230-1



TS-115/230-1: Only compatible with single phase motors up to 1 HP

EXHAUST AND SUPPLY FANS: THE GPX

sales@trianglefans.com ▶ 501-982-7558 ▶ TriangleFans.com