



# FHIR SERIES REVERSIBLE FANS

Triangle's "FHIR" series industrial grade true reversible wall fans come in belt or direct drive models and are ideal for applications that have supply or exhaust needs out of the same fan. Triangle "FHIR" series industrial grade true reversible wall fans come with a true, bidirectional venturi and bi-directional airfoil blades. The combination of the two prevent the traditional loss of performance associated with traditional "reversible" fans.

## Features

- Reversible totally enclosed motor
- Welded construction
- Comes standard with galvanized wall housing
- Comes standard with reversing switch
- Polyester powder coated venturi panel
- Optional temperature control available for some models





## DIRECT DRIVE FHIR

- Reversible totally enclosed motor
- Welded construction
- Comes standard with galvanized wall housing
- Comes standard with reversing switch
- Polyester powder coated venturi panel

Diameter	HP	RPM	Performance			1-Phase	3-Phase
			0.0" SP	0.125" SP	0.25" SP	115/230V	230/460V
30"	1	1160	8,700	8,000	7,000	FHIR3015T-U-DD	FHIR3015T-X-DD
	2	1160	11,500	10,750	9,500	FHIR3017T-U-DD	FHIR3017T-X-DD
36"	1	860	12,500	11,800	8,400	FHIR3615T-U-DD	FHIR3615T-X-DD
	2	1160	13,500	12,700	11,800	FHIR3617T-U-DD	FHIR3617T-X-DD
48"	1	860	14,900	12,700	10,600	FHIR4815T-U-DD	FHIR4815T-X-DD
	2	860	22,200	20,100	17,900	FHIR4817T-U-DD	FHIR4817T-X-DD
	3	860	28,100	26,200	23,900	----	FHIR4818T-X-DD

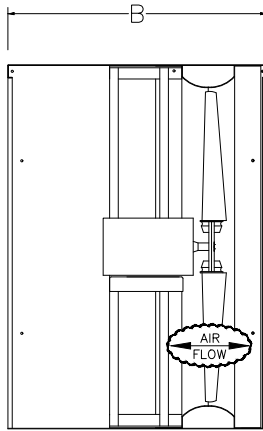
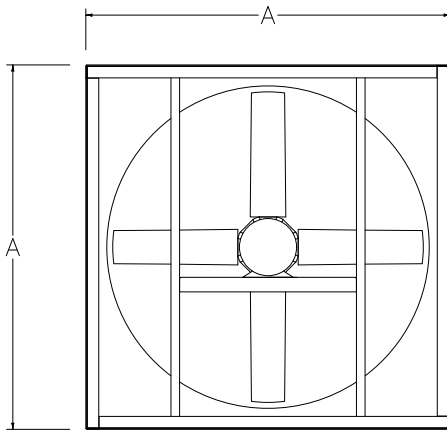

Dimensions "FHIR" Series		
Diameter	A	B
30"	36 3/8"	30"
36"	42 1/4"	30"
48"	54 1/4"	34"

## EXHAUST AND SUPPLY FANS: FHIR DIRECT DRIVE

sales@trianglefans.com ▶ 501-982-7558 ▶ TriangleFans.com



## BELT DRIVE FHIR

- Reversible totally enclosed motor
- Welded construction
- Comes standard with galvanized wall housing
- Comes standard with reversing switch
- Polyester powder coated venturi panel
- Pillow block bearings

Diameter	HP	RPM	Performance			1-Phase	3-Phase
			0.0" SP	0.125" SP	0.25" SP	115/230V	230/460V
30"	1	980	8,400	7,200	5,500	FHIR3015T-U-BD	FHIR3015T-X-BD
	2	1250	10,700	9,800	8,800	FHIR3017T-U-BD	FHIR3017T-X-BD
36"	1	821	11,100	9,800	8,300	FHIR3615T-U-BD	FHIR3615T-X-BD
	2	1035	14,000	13,200	11,900	FHIR3617T-U-BD	FHIR3617T-X-BD
48"	1	493	19,800	16,300	8,500	FHIR4815T-U-BD	FHIR4815T-X-BD
	2	616	24,800	22,100	18,300	FHIR4817T-U-BD	FHIR4817T-X-BD
	3	706	28,300	26,100	23,400	FHIR4818T-U-BD	FHIR4818T-X-BD

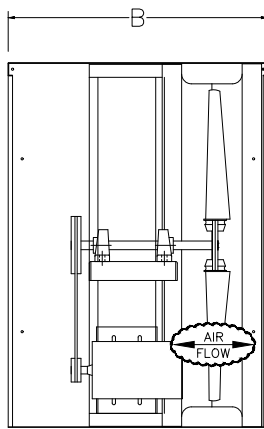
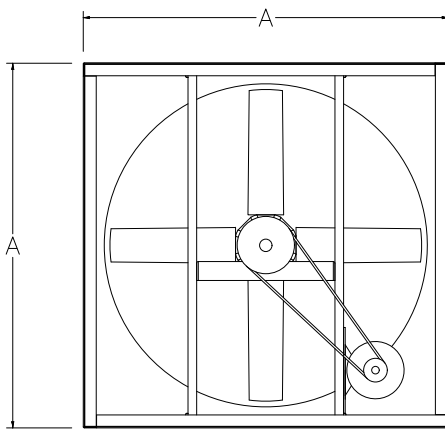

Dimensions "FHIR" Series		
Diameter	A	B
30"	36 3/8"	30"
36"	42 1/4"	30"
48"	54 1/4"	34"

## EXHAUST AND SUPPLY FANS: FHIR DIRECT DRIVE

sales@trianglefans.com ▶ 501-982-7558 ▶ TriangleFans.com