



THE FHI SERIES

Triangles “FHI” series severe duty supply or exhaust fans come in belt or direct drive models and are ideal for applications that have higher performance requirements. Triangles “FHI” series severe duty fans come standard with cast aluminum airfoil blades and are designed to operate in factories, steel mills, processing facilities, warehouses, and more.

Features

- 16” to 84” blade diameter models available (60” for direct drive)
- 3,610 CFM to 115,800 CFM
- Durable gray polyester powder coat finish
- Deep spun venturi type orifice for quieter, more efficient operation
- Rugged all welded structural frame for added support and lower vibration
- Heavy duty self aligning ball bearing pillow blocks, to ensure long maintenance free operation
- Taper lock bushing between propeller and shaft for ease of removal, should it become necessary
- Heavy duty V belt drive with cast iron sheaves, dynamically balanced fan and motor sheaves and extra strength V belts
- Split tapered standard drive hubs permit easy removal of the fan from the shaft for maintenance purposes
- Optional temperature control available for some models

FHI DIRECT DRIVE MODELS

Diam	HP	RPM	Performance						Totally Enclosed		Hazardous Location*	
			Tip Speed	0.0 SP	.125 SP	.25 SP	.375 SP	.50 SP	1PH	3PH	1PH	3PH
24"	1/2	1,200	7,230	6,230	5,540	5,150	4,310	3,110	FHI2413T-U-1200-DD	FHI2413T-X-1200-DD	FHI2413HL-U-1200-DD	FHI2413HL-X-1200-DD
	3/4	1,200	7,230	6,940	6,410	5,790	5,050	3,900	FHI2414T-U-1200-DD	FHI2414T-X-1200-DD	FHI2414HL-U-1200-DD	FHI2414HL-X-1200-DD
	1	1,200	7,230	7,270	6,710	6,070	5,790	3,890		FHI2415T-X-1200-DD	FHI2415HL-U-1200-DD	FHI2415HL-X-1200-DD
	1	1,800	11,100	7,410	6,880	6,360	5,790	5,280	FHI2415T-U-1800-DD	FHI2415T-X-1800-DD	FHI2415HL-U-1800-DD	FHI2415HL-X-1800-DD
	1 1/2	1,800	11,100	8,550	8,060	7,480	6,950	6,420	FHI2416T-U-1800-DD	FHI2416T-X-1800-DD	FHI2416HL-U-1800-DD	FHI2416HL-X-1800-DD
	2	1,800	11,100	9,700	9,110	8,570	7,990	7,260	FHI2417T-U-1800-DD	FHI2417T-X-1800-DD	FHI2417HL-U-1800-DD	FHI2417HL-X-1800-DD
30"	1/2	900	6,750	8,230	7,180	5,980	4,010	1,760		FHI3013T-X-900-DD		
	3/4	900	6,750	9,900	8,770	7,370	4,330	2,600		FHI3014T-X-900-DD		
	1	1,200	9,030	9,370	8,660	7,840	6,970	5,920		FHI3015T-X-1200-DD	FHI3015HL-U-1200-DD	FHI3015HL-X-1200-DD
	2	1,200	9,030	13,200	12,400	11,500	10,500	9,330		FHI3017T-X-1200-DD		FHI3017HL-X-1200-DD
	3	1,800	13,700	14,300	13,800	13,300	12,800	12,300	FHI3018T-U-1800-DD	FHI3018T-X-1800-DD	FHI3018HL-U-1800-DD	FHI3018HL-X-1800-DD
36"	3/4	900	8,110	12,900	11,400	9,570	7,350	4,140		FHI3614T-X-900-DD		
	1	900	8,110	14,800	13,300	11,500	9,300	5,790		FHI3615T-X-900-DD		
	2	1,200	10,800	18,600	17,400	16,200	14,900	13,400		FHI3617T-X-1200-DD		FHI3617HL-X-1200-DD
	3	1,200	10,800	21,000	19,900	18,600	17,300	15,700	FHI3618T-U-1200-DD	FHI3618T-X-1200-DD		FHI3618HL-X-1200-DD
	5	1,200	10,800	24,100	22,800	21,300	19,300	16,900		FHI3619T-X-1200-DD		FHI3619HL-X-1200-DD
	7 1/2	1,200	10,800	26,600	25,400	24,200	23,200	22,100		FHI361AT-X-1200-DD		FHI361AHL-X-1200-DD
42"	2	900	9,460	16,100	15,200	14,300	13,400	12,400		FHI4217T-X-900-DD		
	5	900	9,460	27,900	27,000	26,000	25,000	24,000		FHI4219T-X-900-DD		
		1,200	12,600	28,700	27,700	26,700	25,500	24,200		FHI4219T-X-1200-DD		FHI4219HL-X-1200-DD
48"	3 HP	900	10,800	30,200	27,800	26,100	23,900	19,400		FHI4818T-X-900-DD		
	5 HP	900	10,800	31,400	30,400	29,500	28,500	27,400		FHI4819T-X-900-DD		
	7 1/2	900	10,800	38,700	37,700	36,700	35,700	34,500		FHI481AT-X-900-DD		
	10 HP	1,200	14,500	38,500	37,800	37,000	36,300	35,600		FHI481BT-X-1200-DD		FHI481BHL-X-1200-DD
	15 HP	1,200	14,500	48,600	47,800	47,100	46,400	45,700		FHI481CT-X-1200-DD		FHI481CHL-X-1200-DD
54"	5 HP	900	12,200	36,500	35,100	32,900	31,300	28,300		FHI5419T-X-900-DD		
	7 1/2	900	12,200	47,300	46,000	43,400	41,200	38,500		FHI541AT-X-900-DD		
	10	900	12,200	51,800	49,800	48,300	46,200	44,800		FHI541BT-X-900-DD		
60"	5	900	13,500	38,700	36,300	34,300	31,900	29,500		FHI6019T-X-900-DD		
	7 1/2	900	13,500	44,000	42,300	40,600	39,000	37,300		FHI601AT-X-900-DD		
	10 HP	900	13,500	48,800	47,100	45,500	43,800	42,100		FHI601BT-X-900-DD		

*See the Triangle Catalog for information on hazardous location models.

FHI BELT DRIVE MODELS

Diam	HP	Performance						Totally Enclosed		Hazardous Location*	
		Tip Speed	0.0 SP	.125 SP	.25 SP	.375 SP	.50 SP	1PH	3PH	1PH	3PH
24"	1/2	6,660	5,480	4,920	4,310	3,520	2,030	FHI2413T-U-BD	FHI2413T-X-BD	FHI2413HL-U-BD	FHI2413HL-X-BD
	3/4	7,540	6,150	5,660	5,120	4,530	3,750	FHI2414T-U-BD	FHI2414T-X-BD	FHI2414HL-U-BD	FHI2414HL-X-BD
	1	8,170	6,880	6,450	5,980	5,490	4,920	FHI2415T-U-BD	FHI2415T-X-BD	FHI2415HL-U-BD	FHI2415HL-X-BD
	1 1/2	9,420	8,340	7,960	7,570	7,140	6,670	FHI2416T-U-BD	FHI2416T-X-BD	FHI2416HL-U-BD	FHI2416HL-X-BD
	2	10,600	9,230	8,890	8,550	8,170	7,770	FHI2417T-U-BD	FHI2417T-X-BD	FHI2417HL-U-BD	FHI2417HL-X-BD
30"	1/2	6,940	8,380	7,130	5,020	3,570	2,130	FHI3013T-U-BD	FHI3013T-X-BD	FHI3013HL-U-BD	FHI3013HL-X-BD
	3/4	6,990	9,810	8,730	7,430	5,820	2,990	FHI3014T-U-BD	FHI3014T-X-BD	FHI3014HL-U-BD	FHI3014HL-X-BD
	1	7,700	10,800	9,830	8,690	7,410	4,850	FHI3015T-U-BD	FHI3015T-X-BD	FHI3015HL-U-BD	FHI3015HL-X-BD
	1 1/2	8,640	11,500	10,700	9,800	8,820	7,700	FHI3016T-U-BD	FHI3016T-X-BD	FHI3016HL-U-BD	FHI3016HL-X-BD
	2	9,820	13,800	13,000	12,200	11,300	10,400	FHI3017T-U-BD	FHI3017T-X-BD	FHI3017HL-U-BD	FHI3017HL-X-BD
	3	11,400	16,100	15,000	14,800	14,100	13,300	FHI3018T-U-BD	FHI3018T-X-BD	FHI3018HL-U-BD	FHI3018HL-X-BD
	5	13,700	18,200	17,800	17,300	16,700	16,100		FHI3019T-X-BD		FHI3019HL-X-BD
36"	1	7,730	14,200	12,500	10,600	7,940	4,620	FHI3615T-U-BD	FHI3615T-X-BD	FHI3615HL-U-BD	FHI3615HL-X-BD
	1 1/2	8,860	16,200	14,800	13,300	11,400	8,610	FHI3616T-U-BD	FHI3616T-X-BD	FHI3616HL-U-BD	FHI3616HL-X-BD
	2	9,710	17,800	16,600	15,300	13,700	11,900	FHI3617T-U-BD	FHI3617T-X-BD	FHI3617HL-U-BD	FHI3617HL-X-BD
	3	11,000	20,300	19,200	18,000	16,800	15,400	FHI3618T-U-BD	FHI3618T-X-BD	FHI3618HL-U-BD	FHI3618HL-X-BD
	5	13,200	24,100	23,100	22,200	21,200	20,200		FHI3619T-X-BD		FHI3619HL-X-BD
	7 1/2	15,100	27,700	26,900	26,100	25,200	24,400		FHI361AT-X-BD		FHI361AHL-X-BD
42"	1	7,030	15,500	14,000	12,100	9,400	5,100	FHI4215T-U-BD	FHI4215T-X-BD	FHI4215HL-U-BD	FHI4215HL-X-BD
	1 1/2	6,120	18,000	16,000	13,600	9,900	5,900	FHI4216T-U-BD	FHI4216T-X-BD	FHI4216HL-U-BD	FHI4216HL-X-BD
	2	6,980	20,500	18,700	16,900	14,400	9,600	FHI4217T-U-BD	FHI4217T-X-BD	FHI4217HL-U-BD	FHI4217HL-X-BD
	3	7,810	22,900	21,400	19,800	18,000	15,600	FHI4218T-U-BD	FHI4218T-X-BD	FHI4218HL-U-BD	FHI4218HL-X-BD
	5	9,470	27,800	26,500	25,200	23,900	22,400		FHI4219T-X-BD		FHI4219HL-X-BD
	7 1/2	10,800	31,800	30,600	29,500	28,400	27,300		FHI421AT-X-BD		FHI421AHL-X-BD
	10	12,000	35,300	34,300	33,300	32,300	31,300		FHI421BT-X-BD		FHI421BHL-X-BD
48"	1	7,590	21,200	18,300	13,900	6,300		FHI4815T-U-BD	FHI4815T-X-BD	FHI4815HL-U-BD	FHI4815HL-X-BD
	1 1/2	5,970	22,800	19,800	16,000	8,600	5,200	FHI4816T-U-BD	FHI4816T-X-BD	FHI4816HL-U-BD	FHI4816HL-X-BD
	2	7,110	27,000	24,400	21,500	18,000		FHI4817T-U-BD	FHI4817T-X-BD	FHI4817HL-U-BD	FHI4817HL-X-BD
	3	8,210	31,400	27,000	24,300	21,200	11,100	FHI4818T-U-BD	FHI4818T-X-BD	FHI4818HL-U-BD	FHI4818HL-X-BD
	5	9,610	36,700	34,800	32,900	31,000	28,600		FHI4819T-X-BD		FHI4819HL-X-BD
	7 1/2	11,000	42,100	40,500	38,800	37,200	35,500		FHI481AT-X-BD		FHI481AHL-X-BD
	10	12,100	46,400	44,900	43,400	41,900	40,400		FHI481BT-X-BD		FHI481BHL-X-BD
54"	2	6,930	29,000	25,900	22,000	13,300	7,100	FHI5417T-U-BD	FHI5417T-X-BD	FHI5417HL-U-BD	FHI5417HL-X-BD
	3	7,780	33,200	30,500	27,700	23,700	14,900	FHI5418T-U-BD	FHI5418T-X-BD	FHI5418HL-U-BD	FHI5418HL-X-BD
	5	9,330	39,800	37,500	35,200	32,700	29,400		FHI5419T-X-BD		FHI5419HL-X-BD
	7 1/2	10,700	45,400	43,400	41,400	39,500	37,100		FHI541AT-X-BD		FHI541AHL-X-BD
	10	11,700	49,700	47,900	46,100	44,300	42,400		FHI541BT-X-BD		FHI541BHL-X-BD
60"	2	7,460	33,300	28,900	23,100	14,000		FHI6017T-U-BD	FHI6017T-X-BD	FHI6017HL-U-BD	FHI6017HL-X-BD
	3	6,440	34,400	30,700	25,900	16,800		FHI6018T-U-BD	FHI6018T-X-BD	FHI6018HL-U-BD	FHI6018HL-X-BD
	5	8,010	43,300	40,300	37,100	33,200	28,000		FHI6019T-X-BD		FHI6019HL-X-BD

*See the Triangle Catalog for information on hazardous location models.

FHI BELT DRIVE MODELS

Diam	HP	Performance						Totally Enclosed		Hazardous Location*	
		Tip Speed	0.0 SP	.125 SP	.25 SP	.375 SP	.50 SP	1PH	3PH	1PH	3PH
60"	7 1/2 HP	9,580	51,200	48,700	46,200	43,300	40,000		FHI601AT-X-BD		FHI601AHL-X-BD
	10 HP	10,400	55,400	53,000	50,700	48,200	45,200		FHI601BT-X-BD		FHI601BHL-X-BD
	15 HP	12,000	64,300	62,200	60,200	58,200	56,100		FHI601CT-X-BD		FHI601CHL-X-BD
72"	3 HP	9,610	46,800	40,800	33,600	23,600	12,400	FHI7218T-U-BD	FHI7218T-X-BD	FHI7218HL-U-BD	FHI7218HL-X-BD
	5 HP	7,730	54,500	48,500	42,000	33,000	18,000		FHI7219T-X-BD		FHI7219HL-X-BD
	7 1/2 HP	9,610	63,100	58,000	52,600	46,500	38,600		FHI721AT-X-BD		FHI721AHL-X-BD
	10 HP	11,900	70,300	66,100	61,600	57,100	51,700		FHI721BT-X-BD		FHI721BHL-X-BD
	15 HP	10,400	77,500	74,000	70,500	67,000	62,800		FHI721CT-X-BD		FHI721CHL-X-BD
	20 HP	11,500	86,000	82,800	79,600	76,500	73,300		FHI721DT-X-BD		FHI721DHL-X-BD
84"	5 HP	7,480	64,800	56,400	46,800	34,500	15,200		FHI8419T-X-BD		FHI8419HL-X-BD
	7 1/2 HP	9,020	78,100	71,200	63,900	55,700	45,800		FHI841AT-X-BD		FHI841AHL-X-BD
	10 HP	9,700	84,000	77,600	71,100	63,500	55,500		FHI841BT-X-BD		FHI841BHL-X-BD
	15 HP	11,200	97,200	91,600	86,000	80,100	73,500		FHI841CT-X-BD		FHI841CHL-X-BD
	20 HP	11,900	108,600	103,300	98,000	92,500	86,500		FHI841DT-X-BD		FHI841DHL-X-BD
	25 HP	12,300	115,800	110,400	104,900	99,500	93,800		FHI841ET-X-BD		FHI841EHL-X-BD

*See the Triangle Catalog for information on hazardous location models.

FHI SERIES WALL BOXES

Standard sizes for use
with FHI Belt Drive
and Direct Drive Fans

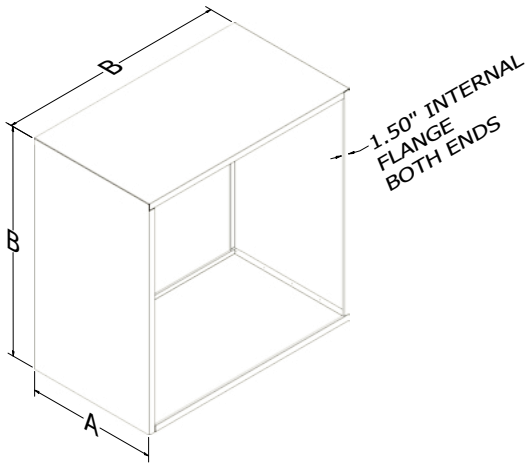

Diameter	A Dimension	B Dimension
24	Varier by Horsepower	30-3/8" O.D.
30		36-3/8" O.D.
36		42-3/8" O.D.
42		48-3/8" O.D.
48		54-3/8" O.D.
54		60-3/8" O.D.
60		66-3/8" O.D.
72		78-3/8" O.D.
84		90-3/8" O.D.

Note: When installation of fan requires a shutter, a minimum of 6" should be allowed between fan blade and shutter. Consult factory for special applications and sizes.

FHI DIRECT DRIVE DIMENSIONS

FAN MODEL	MOTOR HP	PROPELLER		DIMENSIONS			
		RPM	DIA.	A	B	C	D
FHI-24-DD	1/2	1150	24	30	16-1/2	9-1/2	3
FHI-24-DD	3/4	1150	24	30	16-1/2	9-1/2	3
FHI-24-DD	1	1150	24	30	16-1/2	9-1/2	3
FHI-24-DD	1-1/2	1750	24	30	16-1/2	9-1/2	3
FHI-30-DD	1/2	860	30	36	17-1/2	10-1/2	3
FHI-30-DD	3/4	860	30	36	17-1/2	10-1/2	3
FHI-30-DD	1	1150	30	36	17-1/2	10-1/2	3
FHI-30-DD	2	1150	30	36	17-1/2	10-1/2	3
FHI-30-DD	3	1750	30	36	17-1/2	10-1/2	3
FHI-36-DD	3/4	860	36	42	17-1/2	10-1/2	3
FHI-36-DD	1	860	36	42	17-1/2	10-1/2	3
FHI-36-DD	2	1150	36	42	17-1/2	10-1/2	3
FHI-36-DD	3	1150	36	42	20	13	3
FHI-36-DD	5	1150	36	42	20	13	3
FHI-36-DD	7-1/2	1150	36	42	20	13	3
FHI-42-DD	2	860	42	48	22	15	3
FHI-42-DD	5	860	42	48	22	15	3
FHI-42-DD	5	1150	42	48	22	15	3
FHI-42-DD	7-1/2	1150	42	48	22	15	3
FHI-42-DD	10	1150	42	48	22	15	3
FHI-48-DD	3	860	48	54	22	13	3
FHI-48-DD	5	860	48	54	22	15	3
FHI-48-DD	7-1/2	860	48	54	22	15	3
FHI-48-DD	7-1/2	1150	48	54	22	15	3
FHI-48-DD	10	1150	48	54	23-1/2	16-1/2	3
FHI-48-DD	15	1150	48	54	23-1/2	16-1/2	3
FHI-54-DD	5	860	54	60	22	15	3
FHI-54-DD	7-1/2	860	54	60	22	15	3
FHI-54-DD	10	860	54	60	23-1/2	16-1/2	3
FHI-60-DD	5	860	60	66	22	15	4
FHI-60-DD	7-1/2	860	60	66	23-1/2	16-1/2	4
FHI-60-DD	10	860	60	66	23-3/4	15-1/2	4

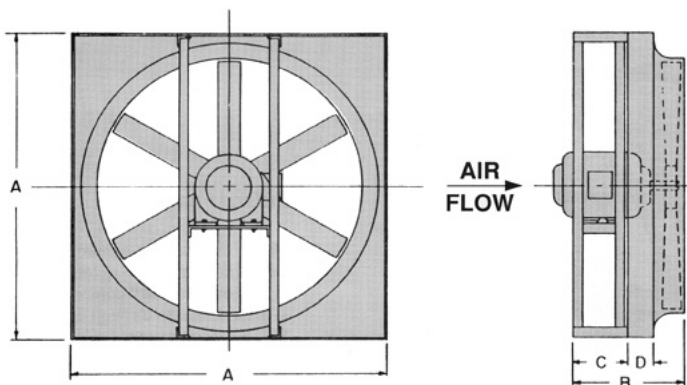

ALL ANGLE OPERATION:
Fan can be mounted vertically in a wall, horizontally in a roof with appropriate hood cover, or at any intermediate angle

FHI BELT DRIVE DIMENSIONS

FAN MODEL	MOTOR HP	PROPELLER		DIMENSIONS			
		RPM	DIA.	A	B	C	D
FHI-24-BD	1/2	1063	24	30	16-1/2	9-1/2	3
FHI-24-BD	3/4	1193	24	30	16-1/2	9-1/2	3
FHI-24-BD	1	1335	24	30	16-1/2	9-1/2	3
FHI-24-BD	1-1/2	1529	24	30	16-1/2	9-1/2	3
FHI-24-BD	2	1693	24	30	16-1/2	9-1/2	3
FHI-30-BD	1/2	891	30	36	17-1/2	10-1/2	3
FHI-30-BD	3/4	884	30	36	17-1/2	10-1/2	3
FHI-30-BD	1	980	30	36	17-1/2	10-1/2	3
FHI-30-BD	1-1/2	1118	30	36	17-1/2	10-1/2	3
FHI-30-BD	2	1250	30	36	17-1/2	10-1/2	3
FHI-30-BD	3	1462	30	36	17-1/2	10-1/2	3
FHI-30-BD	5	1773	30	36	17-1/2	10-1/2	3
FHI-36-BD	1	821	36	42	20	13	3
FHI-36-BD	1-1/2	939	36	42	20	13	3
FHI-36-BD	2	1035	36	42	20	13	3
FHI-36-BD	3	1177	36	42	20	13	3
FHI-36-BD	5	1396	36	42	20	13	3
FHI-36-BD	7-1/2	1607	36	42	20	13	3
FHI-42-BD	1	564	42	48	22	15	3
FHI-42-BD	1-1/2	617	42	48	22	15	3
FHI-42-BD	2	678	42	48	22	15	3
FHI-42-BD	3	776	42	48	22	15	3
FHI-42-BD	5	928	42	48	22	15	3
FHI-42-BD	7-1/2	1073	42	48	22	15	3
FHI-42-BD	10	1192	42	48	22	15	3
FHI-48-BD	1	493	48	54	22	15	3
FHI-48-BD	1-1/2	560	48	54	22	15	3
FHI-48-BD	2	616	48	54	22	15	3
FHI-48-BD	3	706	48	54	22	15	3
FHI-48-BD	5	836	48	54	22	15	3
FHI-48-BD	7-1/2	962	48	54	22	15	3
FHI-48-BD	10	1062	48	54	22	15	3
FHI-54-BD	2	560	54	60	22	15	3
FHI-54-BD	3	641	54	60	22	15	3
FHI-54-BD	5	761	54	60	22	15	3
FHI-54-BD	7-1/2	872	54	60	22	15	3
FHI-54-BD	10	962	54	60	22	15	3
FHI-60-BD	2	500	60	66	22	15	4
FHI-60-BD	3	572	60	66	22	15	4
FHI-60-BD	5	679	60	66	22	15	4
FHI-60-BD	7-1/2	777	60	66	22	15	4
FHI-60-BD	10	855	60	66	22	15	4
FHI-72-BD	3	363	72	78	29	18	5
FHI-72-BD	5	427	72	78	29	18	5
FHI-72-BD	7-1/2	488	72	78	29	18	5
FHI-72-BD	10	563	72	78	29	18	5
FHI-72-BD	15	618	72	78	29	18	5
FHI-72-BD	20	690	72	78	29	18	5
FHI-84-BD	5	370	84	90	30	18	6
FHI-84-BD	7-1/2	424	84	90	30	18	6
FHI-84-BD	10	466	84	90	30	18	6
FHI-84-BD	15	534	84	90	30	18	6
FHI-84-BD	20	588	84	90	30	18	6
FHI-84-BD	25	635	84	90	30	18	6

