



THE COMFORT COOLER

Triangle's Comfort Cooler belt drive whole house fans are an efficient, economical way to cool your home. Comfort Cooler whole house fans feature all welded construction for quiet operation. Our Comfort Cooler Fans will cool your home to the outside temperature 5 to 10 times faster than central air conditioning at less than 1/10th the cost!

Features

- Two-speed wall switch and switch plate included
- Automatic belt tensioner
- Deep pitch four-wing propeller for maximum air movement
- Bronze polyester powder coated finish
- Rubber mounted ball bearings sealed for life
- 1" x 4" wood frame with rubber vibration and noise dampener
- Heavy gauge steel welded construction for long life and quieter operation
- UL listed
- Optional 12 hour timer and thermostat available (each sold separately)

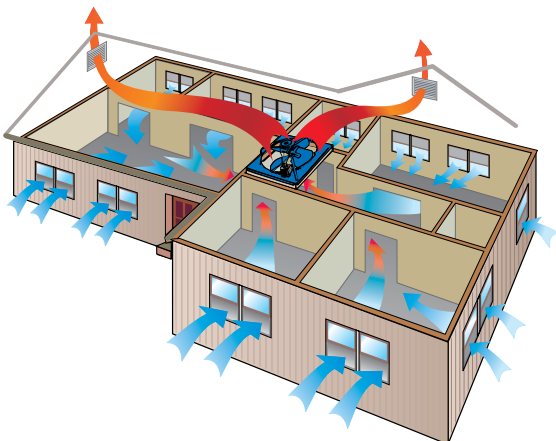

COMFORT COOLER

| BLADE DIAMETER | HP | AMP | RPM HI / LO | CFM HI / LO | Square Footage Cooled | Min Free Exhaust Area Required | SHIP WEIGHT (LBS) | MODEL |
|----------------|-----|-----|-------------|--------------|-----------------------|--------------------------------|-------------------|--------|
| 24 | 1/3 | 6.7 | 560/370 | 5,600/3,700 | up to 800 | 8 sq ft | 57 | CC2422 |
| 30 | 1/3 | 6.7 | 455/305 | 7,600/5,100 | 800-1,200 | 10 sq ft | 64 | CC3022 |
| | 1/2 | 8.2 | 460/305 | 8,400/5,600 | 900-1,500 | 11 sq ft | 69 | CC3023 |
| 36 | 1/3 | 6.7 | 420/280 | 9,700/6,400 | 1,200-1,800 | 12 sq ft | 73 | CC3622 |
| | 1/2 | 8.2 | 415/275 | 10,600/7,100 | 1,500-2,500 | 16 sq ft | 78 | CC3623 |
| 42 | 1/2 | 8.2 | 410/270 | 12,600/8,400 | 2,200-3,200 | 18 sq ft | 85 | CC4223 |
| 48 | 1/2 | 8.2 | 305/200 | 14,500/9,700 | 2,500-4,000 | 22 sq ft | 110 | CC4823 |

| BLADE DIAMETER | DIMENSIONS | | |
|----------------|------------|----|-----|
| | A | B | C |
| 24" | 30" | 4" | 15" |
| 30" | 34" | 4" | 15" |
| 36" | 40" | 4" | 15" |
| 42" | 46" | 4" | 15" |
| 48" | 52" | 4" | 15" |

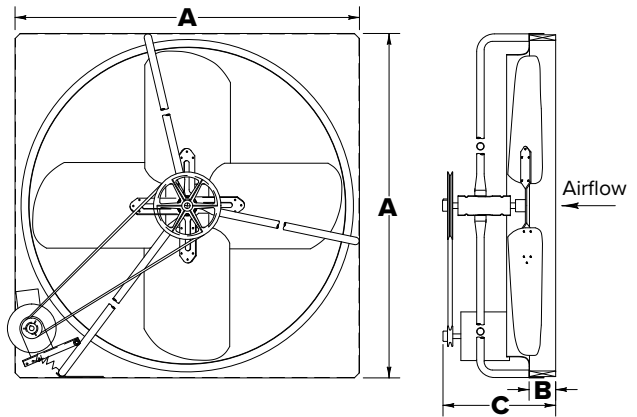

| OPTIONAL TIMER | | OPTIONAL THERMOSTAT | |
|----------------|------------|---------------------|--------------|
| 12 Hour | FG-12HRTIM | 40°F - 110°F | TS-115/230-1 |

| COMFORT COOLER SHUTTER PAIRING GUIDE | | |
|--------------------------------------|--------------------------|----------------------|
| MODEL | Standard Cooling Shutter | No-Cut Joist Shutter |
| 24"CC | AS10 | CSS-24 |
| 30"CC | AS13 | CSS-30 |
| 36"CC | AS16 | CSS-36 |
| 42"CC | AS18 | CSS-42 |
| 48"CC | AS26 | |

TS-115/230-1: Only compatible with single phase motors up to 1 HP



WHOLE HOUSE FANS AND SHUTTERS: COMFORT COOLER

sales@trianglefans.com ▶ 501-982-7558 ▶ TriangleFans.com



STANDARD CEILING SHUTTER

- Heavy duty extruded aluminum frames and louvers
- Polyethylene bearing for smooth, silent operation
- Shutters open and close automatically, keeping out air, insects and dust
- White enamel finish

| Model | Fan Size | Outside Dimensions | Inside Dimensions | Approximate Weight |
|-------|----------|--------------------|-------------------|--------------------|
| AS10 | 24" | 26" x 26" | 24" x 24" | 6 |
| AS13 | 30" | 32" x 38" | 30" x 36" | 9 |
| AS16 | 36" | 34" x 45" | 32" x 43" | 12 |
| AS18 | 42" | 36" x 48" | 34" x 46" | 14 |
| AS26 | 48" | 38" x 58" | 36" x 56" | 16 |



NO-CUT JOIST SHUTTER

- Heavy duty extruded aluminum frames and louvers
- Polyethylene bearing for smooth, silent operation
- Shutters open and close automatically, keeping out air, insects and dust
- White enamel finish

Opening Sizes: Installs centered on a joist with 16" or 24" centers. Cut two openings, one on each side of center joist per shutter model.

| Model | Fan Size | Outside Dimensions | Inside Dimensions | Opening Size | Approximate Weight |
|---------|----------|--------------------|-------------------|-------------------|--------------------|
| CSS-24 | 24" | 24" x 32" | 22" x 30" | 10 1/4" x 30 1/4" | 9 |
| CSS-30 | 30" | 32" x 35" | 30" x 33" | 14 1/4" x 33 1/4" | 10 |
| CSS-36 | 36" | 32" x 43" | 30" x 41" | 14 1/4" x 41 1/4" | 11 |
| CSS-42* | 42" | 38" x 49" | 36" x 47" | 17 1/4" x 47 3/4" | 15 |

*For 24" O.C. joists only

WHOLE HOUSE FANS AND SHUTTERS: SHUTTERS

sales@trianglefans.com ▶ 501-982-7558 ▶ TriangleFans.com