

GPX General Purpose Exhaust Fans

OWNER'S
MANUAL
Read and
save these
instructions

Installation • Operation • Repair parts

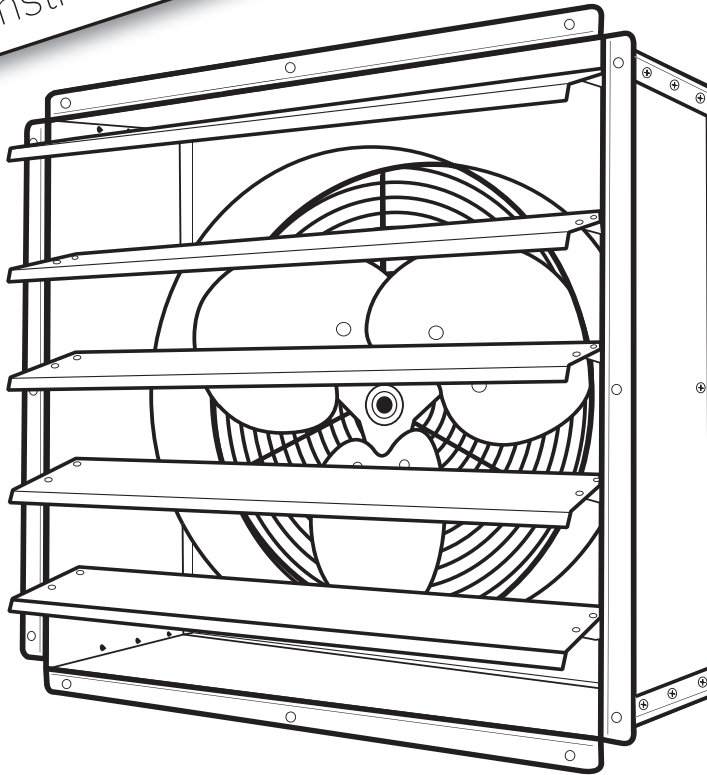

FOR MODELS:

GPX 1210

GPX 1611

GPX 2011

GPX 2413

GPX 3013

OWNER'S RECORD

Please complete for future reference.

Model # _____ Serial # _____

Purchased from _____

Date Purchased _____



TRIANGLE ENGINEERING OF ARKANSAS, INC.

E-mail: mail@trianglefans.com • Website: www.trianglefans.com
1101 North Redmond Road • Jacksonville, Arkansas 72076
(501) 982-7558 • Fax (501) 982-5691 • **1-800-255-9014**

IMPORTANT: READ INSTRUCTIONS CAREFULLY BEFORE ATTEMPTING TO INSTALL, OPERATE OR SERVICE THIS FAN. FAILURE TO COMPLY WITH INSTRUCTIONS COULD RESULT IN PERSONAL INJURY AND/OR PROPERTY DAMAGE.

Proper installation is required to achieve maximum efficiency. It is necessary to provide adequate ventilation to meet minimum intake air requirements. This prevents pressure buildup, which will reduce the fan's efficiency. Inadequate intake air can also lead to premature motor failure.

CAUTION - SAFETY RULES

WARNING: TO REDUCE THE RISK OF FIRE, ELECTRIC SHOCK OR INJURY, OBSERVE THE FOLLOWING:

- Use this unit only in the manner intended by the manufacturer. If you have questions, please contact manufacturer.
- Before servicing or cleaning unit, switch power off at service panel and tag service panel to prevent power from being switched on accidentally.
- Installation and electrical wiring must be done by qualified person(s) in accordance with all applicable codes and standards, including fire-rated construction.
- Sufficient air is needed for proper combustion and exhausting of gasses through the flue (chimney) of fuel-burning equipment to prevent back-drafting. Follow the heating equipment manufacturer's guidelines, along with safety standards such as those published by the National Fire Protection Agency (NFPA), the American Society for Heating, Refrigeration & Air Conditioning Engineers (ASHRAE), and your local code authorities.
- **CAUTION** Check for hidden electrical wiring or utility lines before cutting or drilling into a wall or ceiling.
- **CAUTION** For general ventilating only. DO NOT use to exhaust hazardous or explosive materials.
- Your GPX fan will operate only on 120 volt AC, 60Hz (cycle) current.
- A permanent, THREE-WIRE (ground-

ed) wiring must be used. DO NOT USE AN EXTENSION CORD.

- To avoid risk of fire, electrical shock and other injuries, switch power off at service panel and tag prior to the installation.
- Do not operate fan in areas where gas or oil-fired equipment is in operation.
- Wear safety goggles when drilling, hammering, or cutting materials.

OPERATING YOUR FAN

IMPORTANT Do not operate your fan without first providing adequate ventilation (such as a door or window) to provide the proper inlet airflow.

WARNING BEFORE PROCEEDING WITH THE INSTALLATION, SWITCH POWER OFF AT SERVICE PANEL. The fan requires a 120-volt AC power source with at least 5-amp capacity (10-amp for 24" and 30" GPX). All electrical work must be done in accordance with local building codes, using approved material. Follow the wiring diagram shown on next page.

ITEMS REQUIRED FOR INSTALLATION

- Screwdriver
- Safety goggles
- Measuring tape
- Electric drill
- Power saw or hand saw
- (12) wood screws 1/4" x 3/4" lg.
- Straight edge
- Pencil

GPX FANS ARE EASY TO INSTALL:

1. Simply cut a square opening in the wall. (See chart below).
2. Slide the fan into the opening from outside the structure. Using (12) 1/4" x 3/4" screws, attach flange to your structure.
3. Connect the motor to a 120-volt, 60-Hz single-phase power source.

Model	Wall Hole Size
12	17 3/8" square
16	21 3/8" square
20	25 3/8" square
24	29 3/8" square
30	35 3/8" square

WIRING DIAGRAM

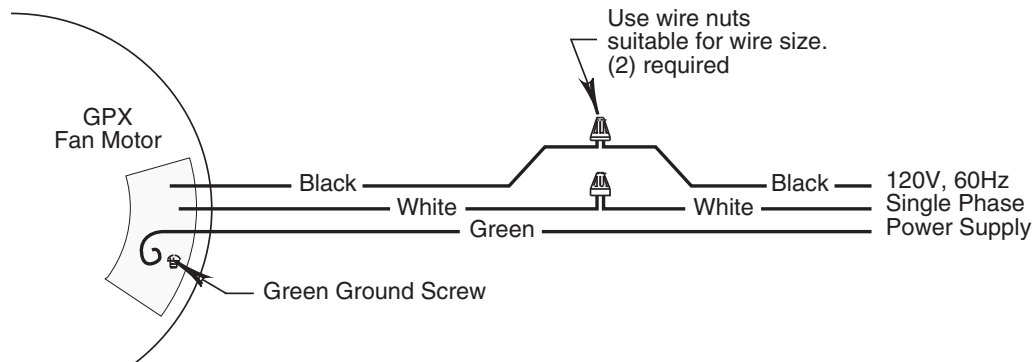

REPAIR PARTS

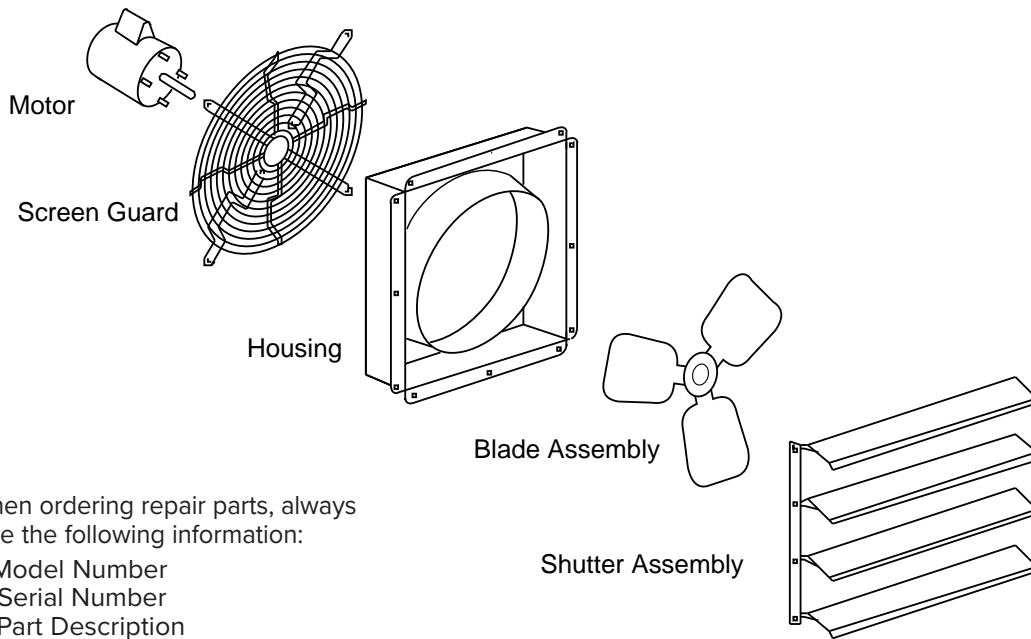

HOUSING DIMENSIONS

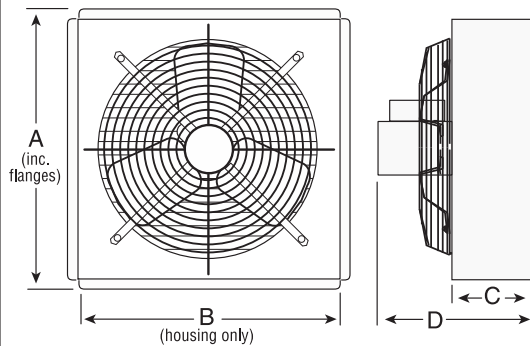

Model	A Square	B Square	C	D	Weight LBS.
GPX 1210	18 ³ / ₄ "	17 ¹ / ₈ "	6"	13 ¹ / ₄ "	35
GPX 1611	22 ³ / ₄ "	21 ¹ / ₈ "	6"	13"	43
GPX 2011	26 ³ / ₄ "	25 ¹ / ₈ "	6"	13"	55
GPX 2413	30 ³ / ₄ "	29 ¹ / ₈ "	6"	14 ¹ / ₄ "	66
GPX 3013	36 ³ / ₄ "	35 ¹ / ₈ "	6"	13"	70

WARNING: TO REDUCE THE RISK OF FIRE OR ELECTRICAL SHOCK DO NOT USE THIS FAN WITH ANY SOLID STATE FAN SPEED CONTROL DEVICE.

TROUBLESHOOTING

Symptom	Possible Cause	Corrective Action
Fan does not operate	Defective Motor	Repair or replace motor
	No power	Inspect power cord for damage. Check fuse or circuit breaker
Insufficient airflow	Intake Guard is excessively dirty	Clean guards.
	Shutter is blocked or not operating	Check shutter for proper operation
	Insufficient airflow	Open window or door.
Squealing, Slapping or Whining noises while operating	Defective motor bearings	Replace motor
	Damaged Blade	Replace fan blade

NOTE: Turning fan on and off in rapid succession will cause motor to over heat. If this occurs allow motor to cool twenty minutes before resuming operation.

MOTOR REPLACEMENT DURING WARRANTY PERIOD.

If the motor on your General Exhaust Fan should fail during the first year of operation, simply remove the LABEL ONLY from the motor and mail to Triangle Engineering, via certified or registered mail. Once the label is received, and if the motor is still under warranty, we will ship a new motor, UPS PREPAID.

DO NOT RETURN MOTOR.

LIMITED ONE YEAR WARRANTY

Triangle Engineering of Arkansas, Inc. (Manufacturer) warrants, from the date of purchase, to the original purchaser only, that the product manufactured by Manufacturer is free from defects in material and workmanship for a period of **ONE (1) YEAR**. Motors, capacitors, v-belts and switches are excluded from this warranty, but shall have a limited one year warranty from date of purchase to the original purchaser.

If a failure of the product occurs, contact the Manufacturer at: 1-800-255-9014 and give the model number of the product, the purchase date, and a description of the problem to the customer service agent.

Once the problem is diagnosed, and proof of purchase date is verified, Manufacturer will have the option of shipping the necessary repair part(s) to the Customer, freight prepaid or having the product returned to Manufacturer for repair or replacement. If the product is returned to the Manufacturer, Customer is responsible for prepayment of all inbound freight charges. Upon repair or replacement, which shall be at the discretion of Manufacturer, the Manufacturer will prepay all outbound freight charges for the return of the product to the customer. However, if Manufacturer finds product to be in operating condition and no problems are diagnosed, product will be returned to customer freight collect.

THERE ARE NO WARRANTIES WHICH EXTEND BEYOND THE DESCRIPTION ON THE FACE HEREOF.

Except as provided by this express warranty, the goods are sold "as is" without any implied warranties.

This limited warranty does not cover labor to replace warranted parts or motors, nor does it cover failure of the installer to provide adequate ventilation to meet minimum exhaust requirements, damage resulting from accident, misuse or abuse, lack of proper maintenance, improper installation, affixing of any parts or attachments not authorized by Manufacturer, or loss of parts.

In no event shall Manufacturer be liable for any special, incidental, or consequential damages; which may result from any defect in material or workmanship.

It is expressly understood that Buyer's sole and exclusive remedy shall be repair or replacement of defective parts, and that Triangle Engineering shall not be liable for injury to persons or property. Should the goods prove so defective, however, as to preclude the remedying of warranted defects by repair or replacement, the Buyer's sole and exclusive remedy shall then be a refund of the purchase price.

This warranty gives you specific legal rights, and you may also have other rights which vary from state to state.